



PANELMASTER LIQUID COOLED RESISTANCE SPOT WELDER

WARNINGS AND SAFEGUARDS FOR WELDING AND CUTTING OPERATIONS

Important - Protect yourself and others! Remember that safety depends on you. The operator, supervisor, and helper must read and understand all warning and safety information provided in these instructions. **Serious injury or death** could result if welding equipment is not properly installed, used and maintained. Training and proper supervision are most important for a safe work place. Installation, operation, repair work, and maintenance must be performed by qualified personnel. Retain these instructions for future use.



ELECTRICAL SHOCK CAN CAUSE INJURY OR DEATH

Install and maintain equipment in accordance with the National Electrical Code NFPA 70 and local codes. Do not service or repair equipment with power on. Do not operate equipment with protective insulators or covers removed. Service or repair to equipment must be done by qualified and/or trained personnel only.

Maintain welding head, work clamps, welding cable, and welding machines and related equipment in good safe operating condition. Replace all worn or damaged insulation. Occasionally, check all connections to determine if they are mechanically strong and electrically adequate for the current required. Never immerse electrodes in water for cooling.

References: See Safety and Operating References A, F, H, & I.



SMOKE, FUMES, AND GASES CAN BE DANGEROUS TO YOUR HEALTH

Keep smoke, fumes, and gases from your breathing zone and the general area. Smoke, fumes, and gases from the welding process are of various types and strengths, depending on the kind of metal being welded on. To ensure your safety, do not breathe these fumes or gases. Ventilation must be adequate to remove smoke, fumes, and gases during the welding procedure to protect operators and others in the immediate area. Fumes produced by welding or cutting, especially in confined areas, can cause discomfort and physical harm if inhaled over an extended period of time. Always provide adequate ventilation in the welding and cutting area to insure breathing air is safe. Use air-supplied respirators if ventilation is not adequate to remove all fumes and gases. Never ventilate with oxygen, because oxygen supports and vigorously accelerates fire.

References: See Safety and Operating References A, B, C, H, & I.



HOT PARTS

Hot parts can cause serious burns. The area at and near the work being welded should be handled with proper gloves. Proper clothing should be worn to prevent spatter from causing burns. Never pick up welded material until it has been properly cooled. *References: See Safety and Operating*

References A, B, H, & I.



CRUSHING

The electrode tips and arms can pinch hands or fingers when they are between them and the switch is activated. Hold the head by both handles when positioning the head for welding. Disconnect air line from the welder before repairing or adjusting components on the welding head.



SPOT WELDING SPARKS CAN CAUSE FIRES AND EXPLOSIONS

Remove any and all combustible materials from the work area. If this is not possible, cover them to prevent the welding sparks from starting a fire. Causes of fire and explosion are any combustibles reached by flying sparks or heated materials. Do not wear any gloves or clothing that has oil or fuel

type material on it. Always have a properly working OSHA recognized Fire Extinguisher near and be sure everyone has proper training in its use.

All hollow spaces, cavities, and containers should be vented prior to welding for they may explode. Make sure proper steps have been taken to ensure that venting procedures will not form flammable or toxic vapors from substances inside containers.

References: See Safety and Operating References A, D, E, F, G, and H.



FALLING EQUIPMENT

Lift only the unit or object to be moved without any running gear, accessories, or gas cylinders that may be attached to it. Use equipment of a proper size to lift and move the unit. Falling equipment can cause personal injury and equipment damage.

References: See Safety and Operating References A, B, H, & I

Safety and Operating References

A) ANSI Z49.1, "Safety in Welding and Cutting"

B) ANSI Z87.1, "Practice for Occupational and Educational Eye and Face Protection"

C) ANSI Z88.2, "Standard Practice for Respiratory Protection"

ANSI: American National Standard Institute, 1430 Broadway, New York, NY 10018

D) ANSI F4.1, "Recommended Safe Practices for Welding and Cutting Containers"

AWS: The American Welding Society, P.O. Box 351040, 550 NW Lejeune RD., Miami, FL 33135

E) NFPA 51B, "Fire Prevention in Cutting and Welding Process"

F) NFPA-70, "National Electrical Code"

NFPA: National Fire Protection Association, Batterymarch Park, Quincy, MA 02269

G) CGA P-1, "Precautions for Safe Handling of Compressed Gases in Cylinders"

CGA: Compressed Gas Association, 1235 Jefferson Davis Hwy., Arlington, VA 22202

H) Code of Federal Regulations (OSHA) 29 CFR 1910

US: U.S. Government Printing Office, Washington, DC 20402

I) CSA Standard W117.2, "Safety in Welding, Cutting, and Allied Processes"

CSA: Canadian Standards Association, 178 Rexdale Blvd., Rexdale, Ontario, Canada M9W 1R3

WARRANTY

LIMITED WARRANTY: Subject to the terms and conditions hereof, NLC, Inc., Jackson, Missouri warrants its products to be free from defects in workmanship and material at the time of delivery by NLC, Inc.

NLC, Inc. will honor warranty claims on products as a result of failure from a defect for a time period of one year from the date of sale to the original user. Upon return of the merchandise at the user's expense, NLC, Inc. reserves the right to either repair or replace as necessary. This is the only warranty either expressed or implied covering our products.

UNPACKING AND ASSEMBLY

Your new Lenco PANELMASTER comes assembled and with some minor preparations, ready to use. Examine the packing material for shipping damage, which may indicate damage to the unit inside. If damage is found, contact the shipper to resolve any issues resulting from shipping. Once you have removed the outer covering from the pallet, unbolt the machine from its bracings and carefully remove it and place on a clean, level surface. Next, check the power supply you intend to use to see if the plug and receptacle will mate properly. **This machine requires single-phase, 208/230 volts, 60/50Hz, and 60-amp service with delayed action breaker. Have the power supply checked by a licensed electrician.** The PANELMASTER also uses compressed air.

Before you hook the machine to the power and air supplies do the following:

- Fill the cooling unit with special coolant supplied (LAS-415). Make sure to save one quart for priming.
- Make certain that the coolant hose fittings are secure at the circulator and at the welding head.

CAUTION: When using the LEN-COOL gun assembly, take care to ensure the electrodes and the other cable assembly are not contacting one another or contacting any conductive material (use enclosed tip covers).

- Plug the air fitting on the welding head into the snap fitting on the front of the PANELMASTER.

To hook the machine to the power and air supplies do the following.

- Attach the shop air supply hose to the male fitting of the air regulator on the back of the PANELMASTER.
- Turn the air pressure on and set the regulator to 70 psi.
- Turn off the breaker to the shop power receptacle, attach the power cord to the shop electrical supply, and then turn the breaker back on.
- Turn on the power switch on the front of the welder and inspect the entire system for air and water leaks. (The cooling unit starts and stops with the power switch.)
- Set the timer control on the front of the machine to 3.
- Set switch for either single side or squeeze type weld procedure.
- Set switch for Automatic Operation.

TEST WELDS

Cut four to six pieces of metal similar to that which you plan to weld, and clean the 2 outside areas to bare metal. Clamp two pieces together and support them so the welding head can clamp across them to make a weld. Remove any combustibles from the area. Also protect any nearby items which could be damaged by flying sparks. Put on your safety glasses and any other required safety gear as needed. Make a test weld. Adjust timer control and air pressure until desired weld is achieved.

SINGLE SIDE WELDING CABLE/GROUND CLAMP

In order to improve performance and operating efficiency of the single side welding function, we have now incorporated a single electrode and ground clamp in place of the "dual spot" system. Because of the amount of power generated by the PANELMASTER, this will allow the user greater control, allowing for a better weld. Instructions for use are as follows:

IMPORTANT: Wear proper welding gloves as the electrode, ground clamp, and area being welded can become very hot.

1. Unplug the switch cord on the front panel of the machine and plug in the switch cord for the single side gun.
2. Set the timer on 2 (you can adjust up or down depending on metal thickness or local line voltage conditions).
3. Connect the ground clamp firmly on the same panel you are welding on.
NOTE: Periodically check to make sure the ½" bolt that connects the ground clamp to the cable lug remains TIGHT. If allowed to work loose, a faulty connection will occur, resulting in overheating and arcing.
4. Press the electrode firmly to the panel with enough pressure to close any gaps.
5. Press the switch on the handle and hold it down until the welding cycle stops automatically.

SINGLE SIDE ELECTRODE CARE AND SERVICE

- **DRESSING THE TIP:** The fastest way to dress the tip is to use the PTS-100 Tip Sharpener. Place the tip sharpener over the electrode as you would a pencil sharpener. Apply pressure and twist the sharpener several revolutions to the right. The hardened tool steel bit will quickly sharpen the copper tip to its original 1/8" diameter. Use a file to dress the face of the welding tip. **KEEP THE TIP DRESSED TO 1/8" DIAMETER FOR CONSISTENT WELDING RESULTS.**
- **REMOVING THE TIP:** Tap the side of the copper electrode gently several times with a bumping hammer to loosen the taper fit. The tip is then normally loose enough to remove by hand. **UNDER NO CIRCUMSTANCES SHOULD YOU ATTEMPT TO REMOVE THE TIP BY TURNING IT IN THE ELECTRODE.** The tip is held in with a No. 1 Morris Taper (No. 4RW) and any attempt to turn it will gall the inside of the electrode which will cause poor contact between the tip and electrode or ruin the electrode.
- **INSERTING TIP:** Wipe the No. 1 Morris Taper (No. 4RW) clean and use the STSW Brush to clean the inside of the electrode. This will clean out any metal filings and corrosion that may have built up inside the electrode. Press the tip in with **HAND PRESSURE ONLY. DO NOT HAMMER THE TIP INTO THE ELECTRODE.** Never insert a "cold" tip into a hot electrode. You should be able to hold the copper electrode body with bare hands before inserting a cold tip.
If by accident you should burn a hole in the panel, it is likely that some steel will be fused to the copper tip. Remove the fused steel by nipping the tip ends with pliers or diagonal cutters. Redress tip with LENCO Tip Sharpener PTS-100 before continuing.
The tips will normally last about 10 months to a year. Reorder new tips from your LENCO distributor.
- **CABLE CONNECTION:** Keep bolts tightened at the welder cable connection. Good contact means good welds.
- **PATCH PANELS:** If patch panels are cut from sheet metal to cover rust areas, make the patch big enough to extend beyond the rust area into good body metal.
In resistance welding, the out-put cables are purposely bound together to deliver more power to the weld. If the bands should become cut, tape the cables so they are always bound together. You will always make good welds, panel after panel, if four conditions are met:
 1. Clean metal
 2. Good fit-up
 3. Proper time setting
 4. Correct tip diameter
- **BURN THROUGH:** Burn through is caused by one of the following:
 1. Paint was not removed from the mating panels.
 2. There were air gaps between the mating metal parts.
 3. The timer setting was too high for the thickness of the metal being welded.
 4. The welding tips were removed from the work before the welding cycle was completed.
 5. The tip diameters were not equal.

The PANELMASTER must be plugged into a 208/230 volt, single phase, 60/50Hz, fused for 60 Amps. In case the PANELMASTER does not operate, check the main fuse box of the building wiring to see if the main circuit fuses are not blown.

WELDING CYCLE FOR THE LEN-COOL GUN

- When the switch on the upper handle is pressed, the tips will compress the panels together. If the button is released the tips will open.
- 1.5 seconds after the tips are closed the microprocessor takes over and welds for the time determined by the timer setting.
- Maintain pressure on the weld for one-half second after the weld is complete, and then release the switch to unclamp the panel.
- In case the above fails to produce a satisfactory weld, check weld area for contact between panels, adjust timer, or air pressure and repeat.

REPLACEMENT PARTS

For all replacement and repair parts information, contact NLC, Inc. (LENCO) directly at 800-747-4743.

NOTES

PARTS DIAGRAM AND ITEM CODE NUMBERS FOR THE PANELMASTER GUN ASSEMBLY

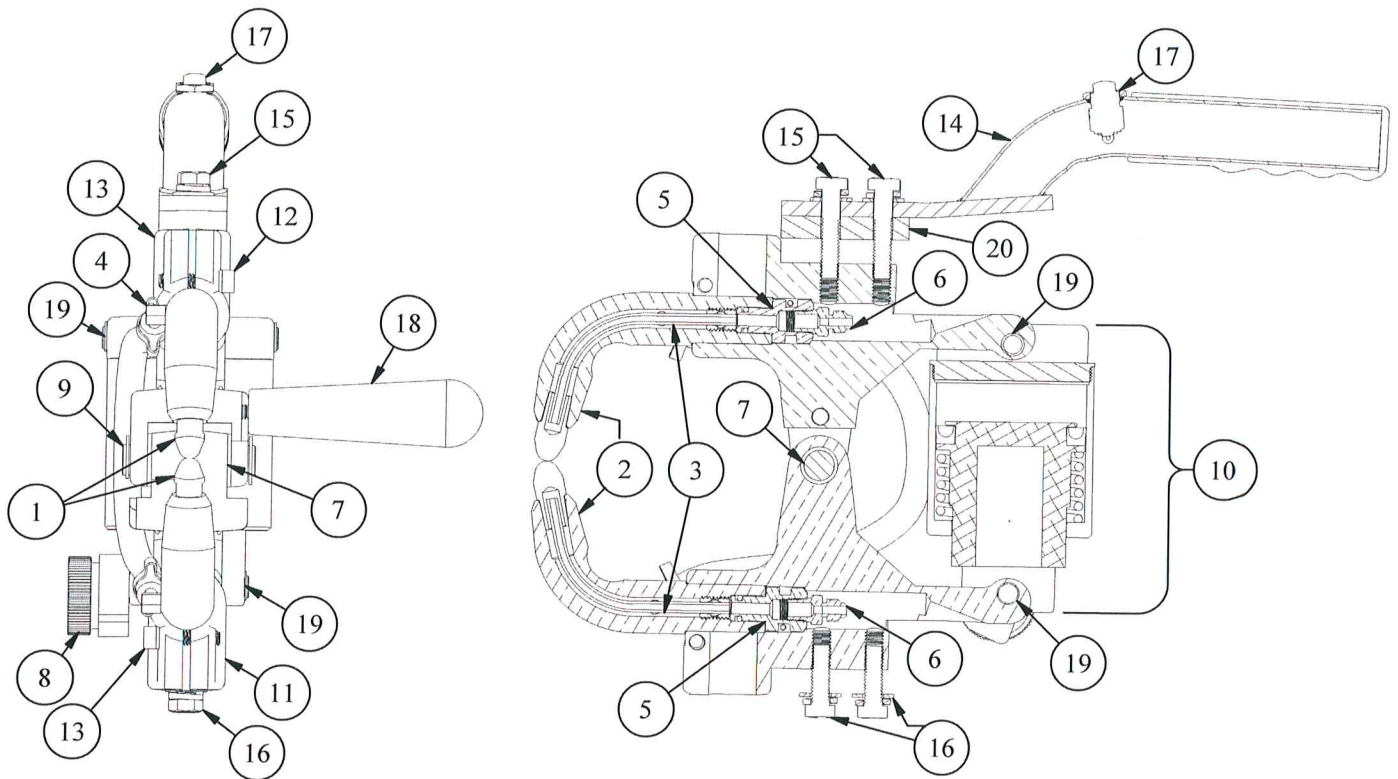

Ref. Number	Part Number	Description
1	26144	Welding Tips (2ea.)
2	26500	Complete Clamp Arm Assembly
3	26505	Clamp Arm Water Tube Assembly
4	26495	Water Hose With 2ea. 90 deg. - 1/16" NPT Hose Fittings
5	26515	2ea. Water Nozzle With "O" Ring
6	26710	2ea. Fitting, Flair - Nozzle
7	26530	2 ea. Insulator Bushings
8	26440	Cam Adjuster With "O" Ring
9	26490	Hinge Pin W/ Clips (2ea.)
10	26460	Air Cylinder Complete
11	26485	Machined Lower Casting
12	26570	2ea. Hex Socket Cap Screws
13	26480	Machined Upper Casting
14	26162	Handle W/ Grip - Rear
15	26550	Hardware Kit - W/ 2ea. 1-1/2 Bolts & W/ 4ea. Washers
16	26551	Hardware Kit - W/ 2ea. 1" Bolts & W/ 4ea. Washers
17	27447	Push Button Switch
18	26163	Handle (central)
19	26470	2ea. Cylinder Hinge Pins With Clips
20	26715	Handle Spacer

PARTS DIAGRAM AND ITEM CODE NUMBERS FOR THE PANELMASTER GUN ASSEMBLY P-130

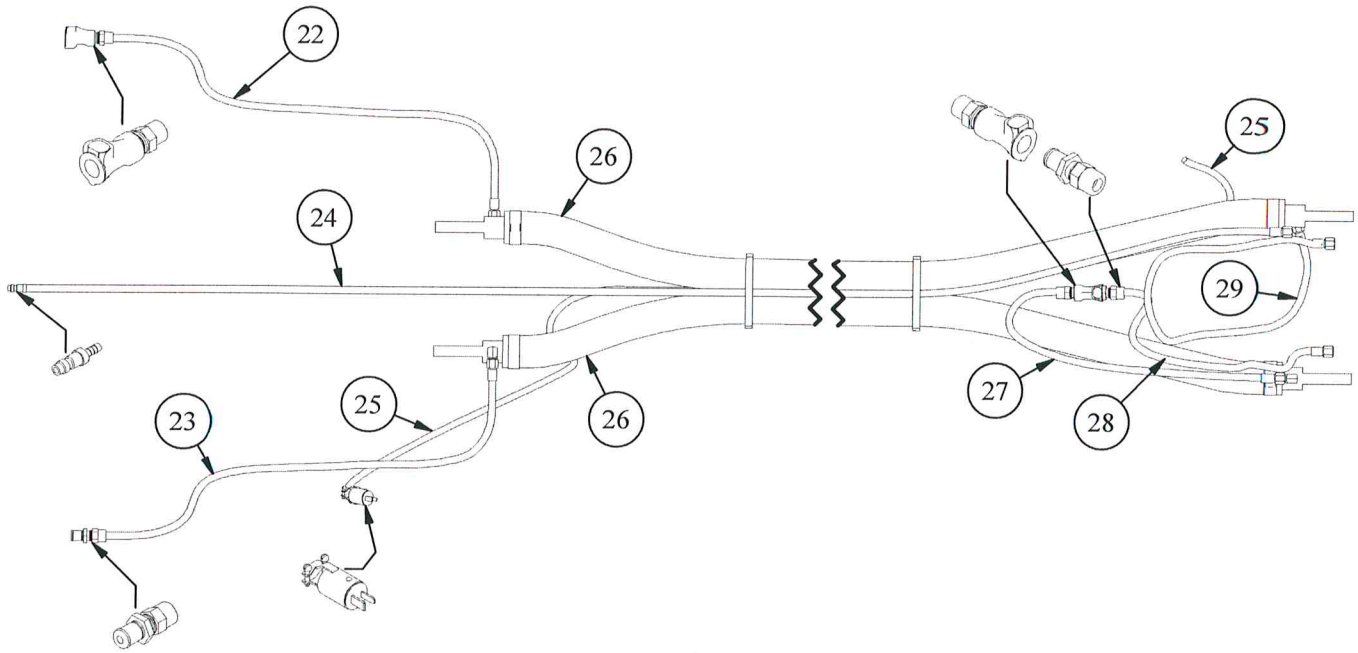

Ref. Number	Part Number	Description
----------------	----------------	-------------

22	26703	P-703 Coolant Hose - Female
23	26704	P-704 Coolant Hose - Male
24	26405	B-405 Hose, Air, With Male Fitting
25	26193	B-193 Control Cord With Plug - 7'
26	26130	P-130 Cables, Water-Cooled
27	26498	B-498 Hose-Electrode To Cable
28	26705	P-705 Coolant Hose-Lug To Gun
29	26701	P701 Coolant Hose-Upper Casting



Lenco Automotive Equipment
For Technical Assistance Call; (800) 747-4743
NLC, INC., 319 W. Main Street, Jackson, MO 63755 Phone (573) 243-3141, Fax (573) 243-7122